



## A force you can rely on

5100/5150 – the next generation of submersible slurry pumps



Flygt



**ITT Industries**  
*Engineered for life*

# When the pumping gets tough, rely on Flygt submersibles



**The removal of abrasive slurry, an essential operation in many industries, makes heavy demands on slurry pumps. Designed to solve the specific problems of pumping high-density slurry, 5100/5150, the next generation of submersible slurry pumps from ITT Flygt, is a cost-effective solution offering true reliability.**

Removing abrasive slurry is a tough job, even for a dedicated slurry pump. Parts wear out, maintenance and repair costs are high. In many cases, frequent pump failures lead to costly production downtime. Also, excessive sediment build-up in a sump costs time and money to remove.

ITT Flygt, the world's leading supplier of submersible pumps and mixers, has focused on solving these problems for years, developing slurry pumps that can handle the toughest, high-wear applications.

### **Why submersibles?**

Flygt submersible slurry pumps offer many advantages over dry-mounted pumps. Operating directly in the slurry, the submersible pump requires no support superstructure. Therefore it occupies less space and installation costs are reduced.

Once installed, the pump requires almost no supervision. Since there are no long or exposed mechanical links between the motor and the volute, less maintenance is required, and operating costs are much lower. A submersible pump is, by definition, completely flood-proof. Also, once submerged, it is virtually silent.

Submersible slurry pumps are often chosen as replacements for dry-mounted pumps where pump failures are frequent and maintenance costs are high. In installations of this type, Flygt slurry pumps have proved to be a reliable alternative, offering continuous operation with low maintenance costs.

### **Handling the toughest jobs**

5100/5150 slurry pumps are a reliable, cost-effective solution for handling the most abrasive slurries in a broad spectrum of tough industrial environments, such as mining and mineral processing, power generation, steel manufacturing and many other sectors.

# The Flygt slurry pump for your specific duty is here

## 5100/5150 performance range

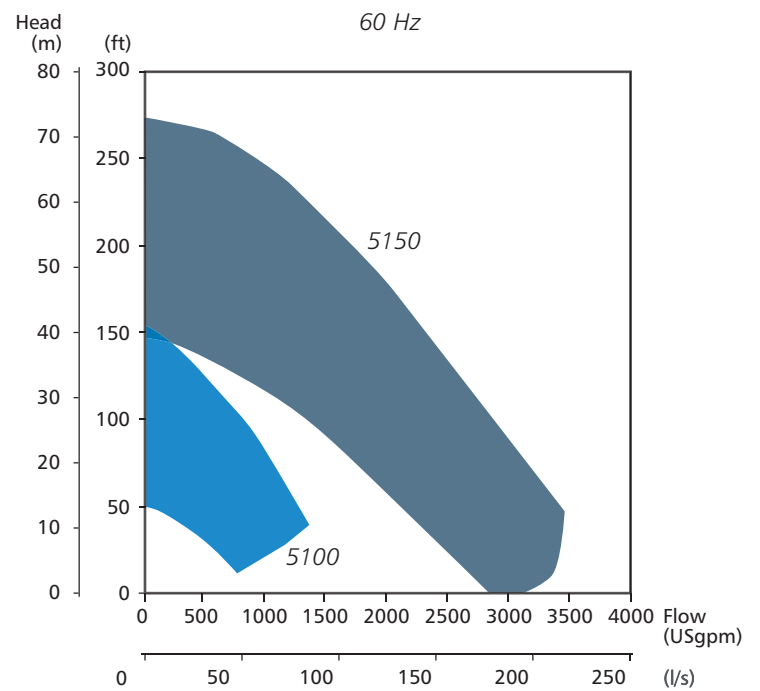
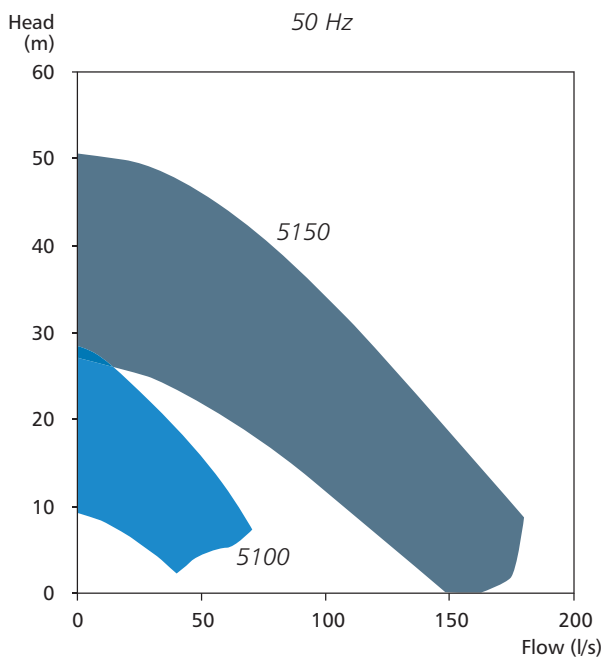

5100/5150 pumps are available with a wide range of motor power ratings. Motors and wet ends are combined to give the optimum solution for your specific duty. The result is trouble-free pumping of high-density slurry and a more cost-effective pumping solution.



5100

Model	Rating	Discharge $\varnothing$	Throughlet $\varnothing$
5100	50Hz, 7.5-45 kW 60Hz, 12-70 Hp	100 mm/4"	40 mm/1.6"
5150	50Hz, 22-70 kW 60Hz, 35-105 Hp	150 mm/6"	50 mm/2.0"



5150

# Cost-effective by design

**Designed for low life-cycle cost**

Slim, robust design makes 5100/5150 pumps easy to install and service, in turn reducing investment and maintenance costs.

**Reliability and long life ensured by wear resistant materials**

Essential for a dedicated slurry pump, all wear parts in the 5100/5150 series are in high chrome. The impeller is hardened for maximum wear resistance. This ensures reliable operation with the most abrasive slurries and a long working life.

**Wide range of motors ensures optimum solution for your duty**

5100/5150 pumps are fitted with efficient, Class H motors as standard, with built-in sensors for high temperature and leakage. Since the submersible motor can handle 15 starts per hour, it can operate in a smaller sump, which means a more flexible installation.

**Lower overall slurry pumping costs due to internal cooling**

An optional internal cooling system means that the pump does not always need to be submerged. It will continue pumping down to low slurry levels, helping to prevent sediment build-up in a sump.

**Early warning system protects your budget**

An inspection chamber between the seal unit and the bearings has a built-in sensor for early detection of any fluid build-up. This reduces the risk of internal damage and increases operational reliability.



**Large throughlets handle solids of varying sizes**

Large throughlets ensure efficient pumping, even when clumps of particles or large pieces of foreign matter pass through the pump.

**High wear resistance, maximum hydraulic efficiency**

The shape of the impeller, with a more sweptback design of the vanes than on a conventional impeller, ensures a more homogenous flow. This minimizes the separation of solids from the carrying fluid, resulting in extremely low wear rates and sustained hydraulic efficiency.

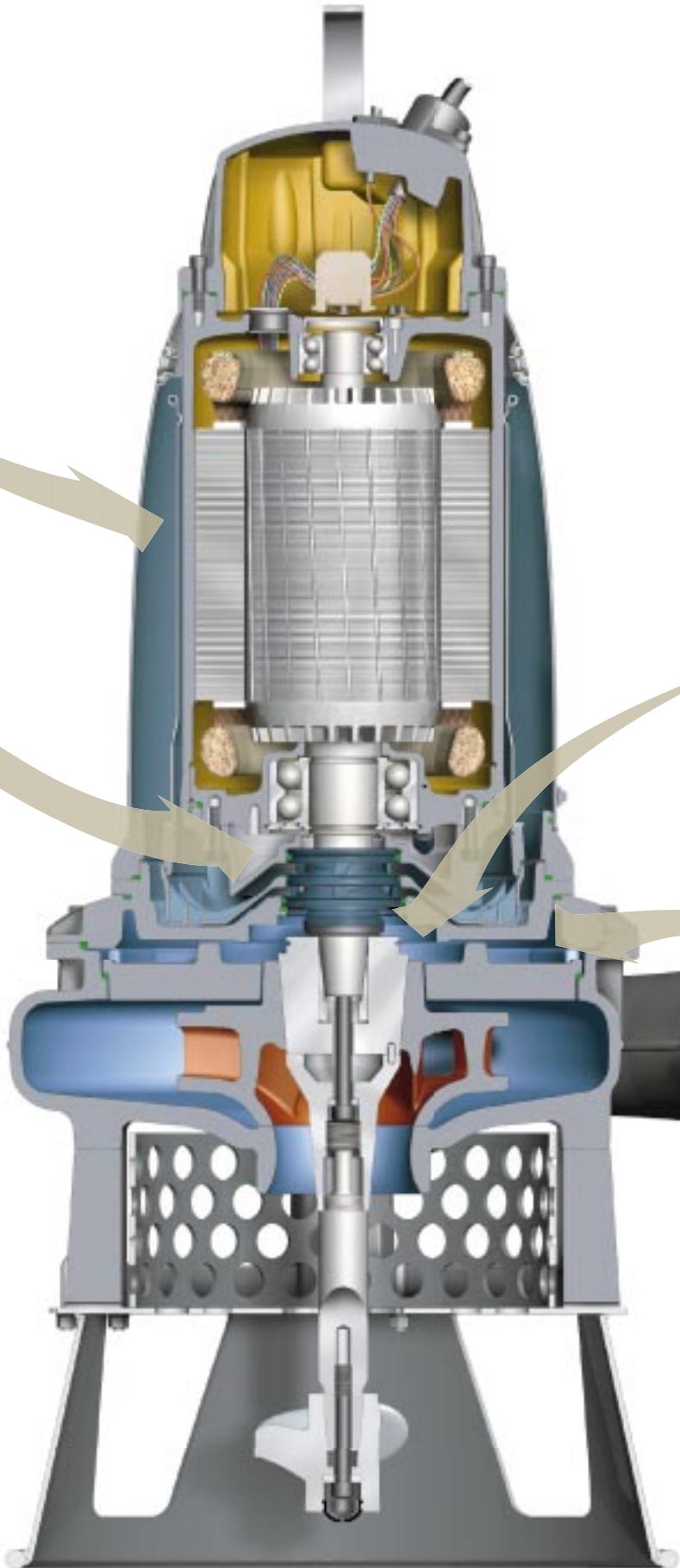

**Plug-in™ seal makes replacement simple**

The Plug-in™ seal system provides a perfect fit and faster, simpler replacement. The design also protects the seal surfaces from contaminants during disassembly and mounting.



**Spin-Out™ seal protection for prolonged seal life and increased reliability**

Spin-out™ is a patented feature that protects the outer seal by expelling abrasive particles from the seal chamber. This prolongs the life of the outer seal unit and increases reliability.

**Additional seal protection**

The impeller hub is equipped with effective pump-out backvanes that expel abrasive particles. There is also a pressure isolation zone. Together, these features provide additional seal protection by reducing pressure in the mechanical seal area.

**Agitator for coarser slurries**

When pumping coarser slurries, like sand, an agitator mounted on the pump shaft helps to prevent solids build-up on the sump floor.

# The flexibility to match your pumping needs

## We call it Clean Sump Technology

### **Agitator for coarser slurries**

When pumping coarser slurries, like sand, an agitator mounted on the pump shaft secures maximum resuspension of settled particles. This makes them easier to transport and ensures a clean sump.

### **Side-mounted mixer for the really tough jobs**

For large sumps with very coarse and heavy particles and/or the need for homogenous slurry, a side-mounted mixer is available. This works in combination with the agitator for the toughest jobs where the agitator alone cannot prevent sediment build-up.

### **Internal cooling reduces sediment build-up**

An optional internal cooling system means that the pump can continue pumping down to low slurry levels. This also helps to prevent sediment build-up in the sump.

### **Let ITT Flygt advise you on pump selection**

At ITT Flygt we have advanced selection tools, test facilities and materials laboratories to help you choose the correct slurry pump for your specific duty. Our system engineering specialists have long experience of system design and pump selection.

We also provide advice and assistance with sump design and the need for an agitator in smaller sumps, or a dedicated mixer in larger sumps.

The bottom line is a cleaner sump at the end of the pumping cycle, and lower overall slurry handling costs.

## Portable and easy to install

### **The ideal solution for most applications**

Standardized for portable, wet installation, 5100/5150 slurry pumps are versatile and easy to install. Each pump is supplied with a built-in support stand and is free-standing, requiring no additional support structure. The Victaulic® flange and coupling allows fast, easy connection to a wide range of commonly available fittings.



*Agitator for coarser slurries.*



*Side-mounted mixer for the really tough jobs.*



*Internal cooling for pumping down to low levels.*

# Service and maintenance



## **Your local service network – worldwide**

The level of maintenance and support that you require from your local service partner will differ according to your

situation. With ITT Flygt you can choose the type of support package that precisely meets your needs.

From simply supplying slurry pumps to your specifications, to full service assistance on system planning, design, construction, implementation, operation or maintenance: ITT Flygt's total service offering means that you get the service you need, on your terms.

## **15-year spare parts availability**

We guarantee availability of spare parts for 15 years after we stop production of a pump model. This is just one of the ways in which ITT Flygt meets its long-term commitment to customers.



